

ITEM	REQD	PART NO.	DESCRIPTION	REMARKS
18	1	216P-2	HEX NIPPLE	PARKER
19	1	F200B-11KT	FLOW CONTROL VALVE	PARKER
20	1	AF350	MUFFLER	GAST MANUF. CORP.
21	1	216P-4-2	HEX NIPPLE-REDUCING	PARKER
22	1	14L11GA	LUBRICATOR	PARKER
23	1	216P-4	HEX NIPPLE	PARKER
24	1	04E11B13FB	FILTER/REGULATOR	PARKER
25	1	111.10.2"	GUAGE	WIKA (0-160 PSI/KPA)

ITEM	REQD	PART NO.	DESCRIPTION	REMARKS
1	1	B-2998-A	BODY	2" WITH CLAMP ENDS
2	1	C-2987-A	FLAVOR TUBE	CUSTOMER TO SPECIFY STYLE
3	1	B-2994-D	LOWER BUSHING	
4	3	A-3000-4	SEAL	
5	2	K13HH-2"	CLAMP	TCI-SUPERIOR
6	2	A-3000-6	"O" RING	-226
7	1	B-2990-A	FLAVOR TEE	2 x 2 WITH CLAMP END
8	1	B-2989-D	UPPER BUSHING	
9	1	A-3000-9	DRIVE PIN	
10	2	A-3000-10	"O" RING	-10
11	1	A-2986-D	COUPLING	
12	1	A-3000-12	SET SCREW	1/4-20 x 1/4" LG. S.S.
13	1	B-2988-A	BONNET	
14	4	A-3000-14	SCREW & LOCKWASHER	10-32 x 3/4" LG. SHCS S.S.
15	1	B-2985-D	ADAPTOR	
16	4	A-3000-23	SCREW	10-32 x 1/2" LG. SHCS S.S.
17	1	1UP-NRV-11-GR11	MOTOR (1/3 HP)	GAST MANUF. CORP.

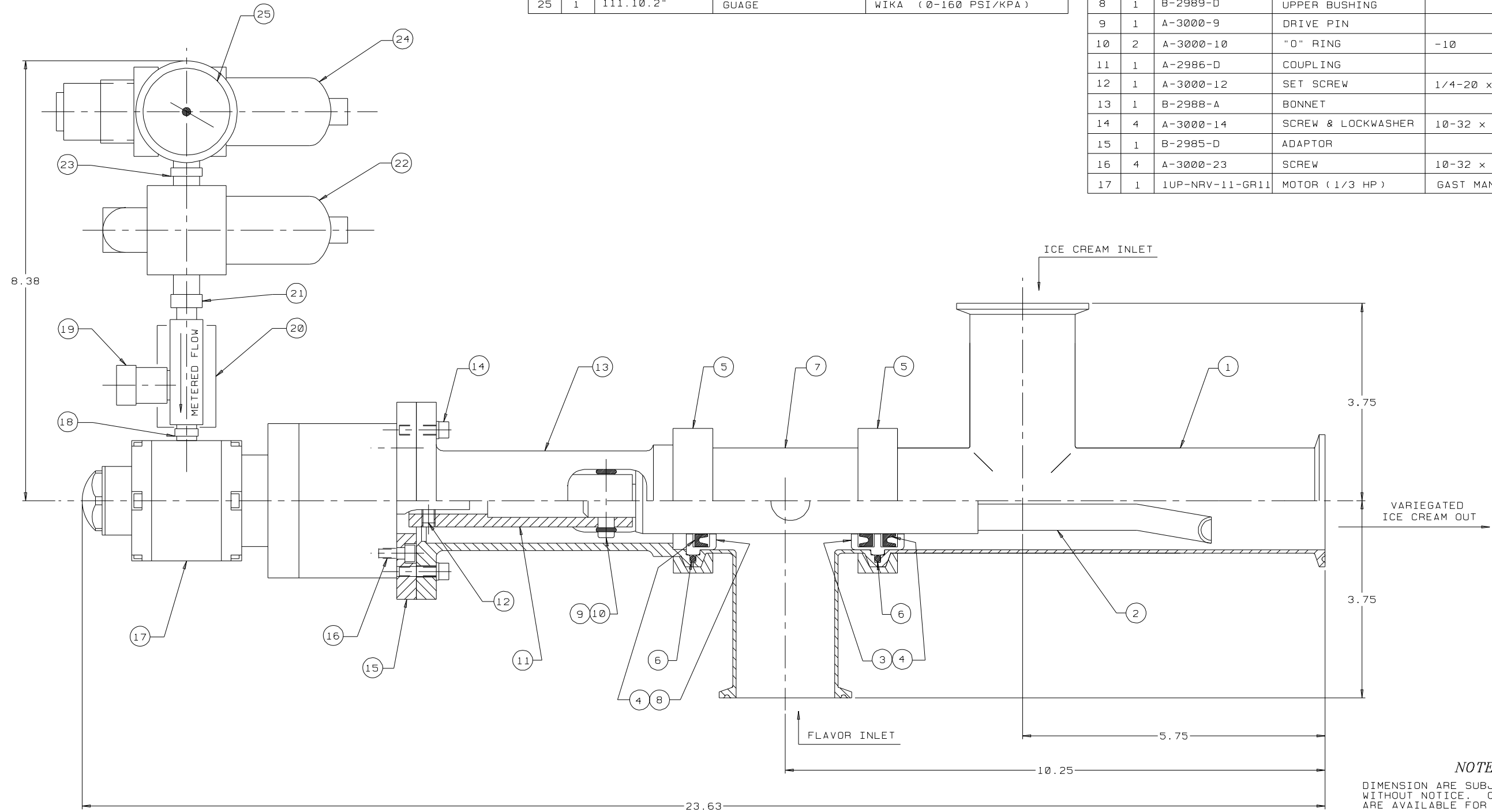

NOTE
 DIMENSION ARE SUBJECT TO CHANGE WITHOUT NOTICE. CERTIFIED DRAWINGS ARE AVAILABLE FOR A NOMINAL CHARGE.

- NOTES:**
1. VARIEGATOR TO BE DISASSEMBLED AND HAND CLEANED DO NOT CLEAN IN PLACE
 2. ALL PRODUCT CONTACT MATERIALS TO BE STAINLESS STEEL TYPE 304, BUNA OR DELRIN
 3. MAXIMUM AIR REQUIREMENTS: 100 PSIG, 20 CFM

<small>THE DRAWING AND INFORMATION CONTAINED ON THIS DOCUMENT IS CONFIDENTIAL AND THE SOLE PROPERTY OF HOLLAND MFG., INC. AND MAY NOT BE REPRODUCED, USED, OR DISCLOSED WITHOUT PRIOR WRITTEN PERMISSION OF AN AUTHORIZED AGENT OF HOLLAND MFG., INC.</small>	
HOLLAND MANUFACTURING, INC. 6851-51 ST. KENOSHA, WIS	
TOLERANCES UNLESS OTHERWISE SPECIFIED 0.000 ±.015 0.000 ±.010 0.000 ±.005 ANGLE ±1 DEG	SCALE: FULL DATE: 1-25-88 BY: SW
VERSACAD DWG VOLUME: FILE #: 03841A	2" SINGLE FLAVOR AIR DRIVE VARIABLE SPEED VARIATOR MODEL ATK-2" SANITARY CLAMP CONNECTIONS
	D-3841-A